



## INSTRUCTION MANUAL

UHF C.R.S. TRANSCEIVER  
**IC-41W**

---

---

---

---

Icom Inc.

---



---

## IMPORTANT

---

**READ ALL INSTRUCTIONS** carefully before using the IC-41W UHF C.R.S. transceiver.

**KEEP THIS INSTRUCTION MANUAL**, as it contains important operating information that may be useful in the future.

---

## EXPLICIT DEFINITIONS

---

WORD	DEFINITION
⚠ <b>DANGER!</b>	Personal death, serious injury or an explosion may occur.
⚠ <b>WARNING!</b>	Personal injury, fire hazard or electric shock may occur.
<b>CAUTION</b>	Equipment damage may occur.
<b>NOTE</b>	If disregarded, inconvenience only. No risk of personal injury, fire or electric shock.

Icom, Icom Inc. and the Icom logo are registered trademarks of Icom Incorporated (Japan) in Japan, the United States, the United Kingdom, Germany, France, Spain, Russia and/or other countries.

---

## GENERAL INFORMATION

---

- i. The Citizen Band Radio Service is licensed in Australia by the ACMA Radiocommunications (Citizens Band Radio Stations) Class Licence and in New Zealand the Ministry of Economic Development New Zealand (MED). Operation is subject to conditions contained in the General User Radio Licence for Citizens Band Radio.
- ii. The transceiver must not be operated on channel 5 and 35, unless in an emergency. No voice transmissions are permitted on channels 22 and 23, as these are used for data (telemetry/telecommand). The transceiver will inhibit transmission on channels 22 and 23.
- iii. Always listen on a channel (or observe channel busy indicator) to ensure it is not already being used before transmitting.
- iv. This transceiver operates on 12.5 kHz channel spacing. During the changeover period from 25 kHz to 12.5 kHz, there may be some loss of quality and/or audio level when 12.5 kHz (narrowband) transmissions are received on 25 kHz (wide band) equipment, and vice-versa. There may also be interference caused by older equipment operating on channels adjacent to narrowband channels, as the channel setting on these may cause some 'overlap.'

---

## PRECAUTIONS

---

**⚠ DANGER! NEVER** short the terminals of the battery pack.

**⚠ DANGER!** Use and charge only specified Icom battery packs with Icom radios or Icom chargers. Only Icom battery packs are tested and approved for use with Icom radios or charged with Icom chargers. Using third-party or counterfeit battery packs or chargers may cause smoke, fire, or cause the battery to burst.

**⚠ WARNING! NEVER** hold the transceiver so that the antenna is very close to, or touching exposed parts of the body, especially the face or eyes, while transmitting. The transceiver will perform best if the microphone is 5 to 10 cm away from the lips and the transceiver is vertical.

**⚠ WARNING! NEVER** operate the transceiver while driving a vehicle. Safe driving requires your full attention—anything less may result in an accident.

**CAUTION: MAKE SURE** the flexible antenna, battery pack and jack cover are securely attached to the transceiver, and that the antenna and battery pack are dry before attachment. Exposing the inside of the transceiver to dust or water will result in serious damage to the transceiver.

**DO NOT** operate the transceiver near unshielded electrical blasting caps or in an explosive atmosphere.

**DO NOT** push [PTT] when not actually intending to transmit.

**DO NOT** use or place the transceiver in direct sunlight or in areas with temperatures below  $-30^{\circ}\text{C}$  or above  $+60^{\circ}\text{C}$ . The basic operations, transmission and reception of the transceiver are guaranteed within the specified operating temperature range. However, the LCD display may not be operate correctly, or show an indication in the case of long hours of operation, or after being placed in extremely cold areas.

**DO NOT** modify the transceiver. The transceiver warranty does not cover any problems caused by unauthorized modification.

**DO NOT** use harsh solvents such as benzine or alcohol when cleaning, as they will damage the transceiver surfaces.

**BE CAREFUL!** The transceiver will become hot when operating it continuously for long periods of time.

---

## PRECAUTIONS (Continued)

---

**BE CAREFUL!** The IC-41W meets IP67\* requirements for dust-tight and waterproof protection. However, once the transceiver has been dropped, dust-tight and waterproof protection cannot be guaranteed because of possible damage to the transceiver's case or the waterproof seal.

\* Only when the jack cover or the optional HM-168LWP is attached.

Even when the transceiver power is OFF, a slight current still flows in the circuits. Remove the battery pack or batteries from the transceiver when not using it for a long time. Otherwise, the installed battery pack or batteries will become exhausted, and will need to be recharged or replaced.

**MAKE SURE** to turn the transceiver power OFF before connecting the supplied/optional equipment.



**N33**

This device complies with Standard Australia Specification No. AS/NZS 4365-2002 and AS/NZS 4295: 2004.

---

# TABLE OF CONTENTS

---

IMPORTANT .....	i	■ Priority Channel.....	10
EXPLICIT DEFINITIONS.....	i	◇ To set the Priority Channel.....	10
GENERAL INFORMATION.....	i	◇ To switch to the Priority Channel.....	10
PRECAUTIONS.....	ii	◇ To cancel the Priority Channel .....	10
TABLE OF CONTENTS.....	iv	■ Monitor.....	10
<b>1 ACCESSORIES.....</b>	<b>1-2</b>	■ Squelch.....	10
■ Supplied Accessories .....	1	<b>4 SET MODE.....</b>	<b>11-15</b>
■ Attaching/Using the Accessories.....	1	◇ Squelch .....	12
◇ Antenna.....	1	◇ CTCSS/DTCS .....	12
◇ Battery Pack.....	1	◇ Auto Power OFF.....	12
◇ Belt Clip.....	2	◇ Backlight.....	12
◇ Jack Cover.....	2	◇ Beep.....	13
<b>2 UNIT DESCRIPTION.....</b>	<b>3-6</b>	◇ Beep Level.....	13
■ Front panel.....	3	◇ Mic Gain .....	13
■ Display.....	5	◇ Battery Voltage .....	13
<b>3 BASIC OPERATION.....</b>	<b>7-10</b>	◇ Signal Monitor .....	13
■ Turning the Power ON .....	7	◇ Power Save .....	13
■ Battery type .....	7	◇ TOT (Time-Out Timer).....	14
■ Backlight.....	8	◇ Lock-out.....	14
■ Keylock .....	8	◇ Scan Resume Timer.....	14
■ Channel/Zone Selection .....	8	◇ Scan Restart .....	14
◇ Channel Selection .....	8	◇ Roger Beep .....	14
◇ Zone Selection (available only when two or more zones are set).....	8	◇ Own ID .....	15
■ Receiving/Transmitting .....	9	<b>5 REPEATER OPERATION .....</b>	<b>16</b>
◇ Receiving.....	9	■ Repeater Operation.....	16
◇ Transmitting.....	9		

---

## TABLE OF CONTENTS (Continued)

---

<b>6 SCAN</b> .....	<b>17–20</b>	<b>9 OTHER FUNCTIONS</b> .....	<b>28–30</b>
■ Scanning Preparation .....	17	◇ Smart Ring/ATS.....	28
◇ Scan type selection .....	17	◇ RX Frequency.....	29
◇ Tag Channel Setting .....	17	◇ PTT Hold .....	30
◇ Scan Resume Condition.....	18	<b>10 BATTERY CHARGING</b> .....	<b>31–35</b>
■ Open Scan.....	18	■ Caution .....	31
■ Group and Priority Scan .....	19	◇ Charging caution .....	32
■ Repeater.....	20	■ Rapid charging with the BC-160.....	33
◇ Repeater search scan flow.....	20	■ Optional battery chargers.....	33
<b>7 TONE SQUELCH</b> .....	<b>21–23</b>	◇ AD-106 installation .....	33
◇ Setting Up a CTCSS/DTCS Code .....	21	◇ Rapid charging with the BC-119N+AD-106.....	34
◇ Turning the tone squelch operation ON or OFF .....	23	◇ Rapid charging with the BC-121N+AD-106.....	34
◇ Setting up and using the pocket Beep.....	23	<b>11 OPTIONS</b> .....	<b>36–39</b>
<b>8 SELCALL (Selective Calling)</b> .....	<b>24–27</b>	■ MB-93 contents .....	36
■ Calling.....	24	■ Attaching.....	36
◇ TX Code Channel Selection .....	24	■ Detaching .....	37
◇ To select a TX code channel .....	24	■ Optional HM-168LWP description .....	38
◇ TX code number edit .....	25	■ Attachment .....	38
■ Receiving.....	26	◇ BATTERY PACK .....	39
◇ Receiving an individual call (default setting) .....	26	◇ CHARGERS.....	39
◇ Recalling a memorised receive selcall code .....	26	◇ BELT CLIPS .....	39
◇ When receiving a group call.....	26	◇ DC CABLES.....	39
■ Quiet Mode.....	27	◇ OTHER OPTIONS.....	39
◇ To monitor the channel.....	27	<b>12 SPECIFICATIONS</b> .....	<b>40</b>
◇ To enable selcall mute.....	27	<b>13 WARRANTY AND REGISTRATION</b> .....	<b>41</b>
■ Stun .....	27		

## ■ Supplied Accessories

AC adapter  
(for the battery charger)

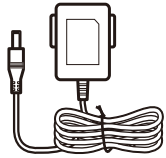

Battery pack

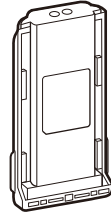

Battery charger

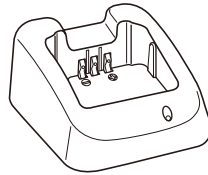

Belt clip



Flexible antenna

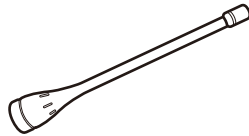

## ■ Attaching/Using the Accessories

### ◇ Antenna

Connect the supplied antenna to the antenna connector as shown.

#### CAUTION:

- **NEVER** carry the transceiver by holding only the antenna.
- **DO NOT** connect the antenna other than listed on page 39.
- Transmitting without an antenna may damage the transceiver.

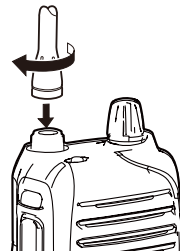

### ◇ Battery Pack

#### To attach the battery pack:

Slide the pack in the direction of the arrow (1), until the battery release button makes a 'click' sound.

NOTE: Push on the bottom of the pack to make sure the release button is firmly locked.

#### To release the battery pack:

Push the battery release button in the direction of the arrow (2), then slide the battery pack out.

NEVER release or attach the battery pack when the unit is wet or soiled. This may result in water or dust getting into the transceiver/battery pack, which may cause damage to the transceiver.

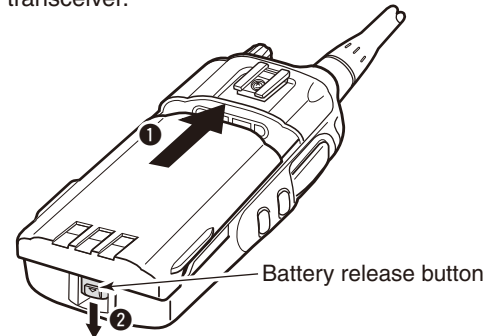

NOTE: Keep the battery terminals clean. It's a good idea to regularly clean them.

# 1 ACCESSORIES

## ◇ Belt Clip

### To attach the belt clip:

- ① Release the battery pack if it is attached.
- ② Slide the belt clip in the direction of the arrow (see below) until a 'click' sound is heard.

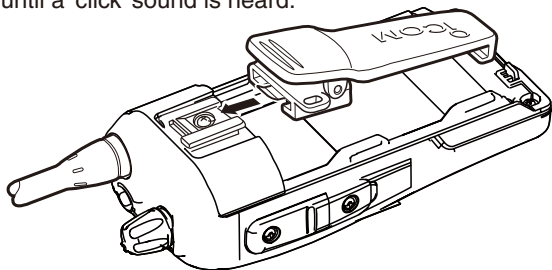

### To detach the belt clip:

- ① Release the battery pack if it is attached.
- ② Pinch to lift the clip at ① (see below) and slide the belt clip out of the holding bracket. (②)

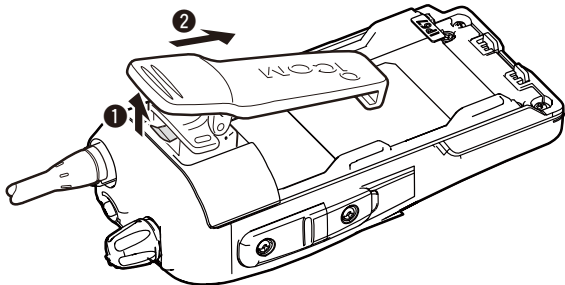

## ◇ Jack cover

### To attach the jack cover:

- ① Attach the jack cover to the [MIC/SP] jack.
- ② Tighten the screws.

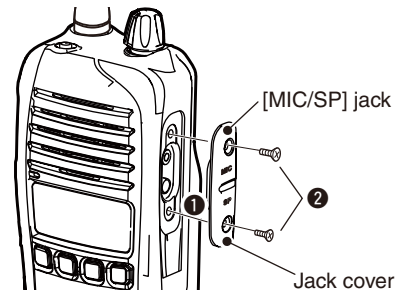

### CAUTION:

- Attach the jack cover when the optional speaker-microphone is not used.
- Use the supplied screws only.

### To detach the jack cover:

- ① Unscrew the screws using a phillips screwdriver.
- ② Detach the jack cover for the speaker-microphone.

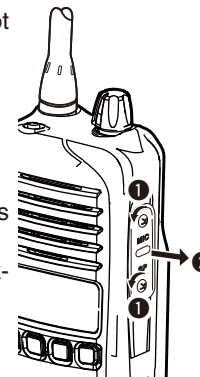



## ■ Front panel

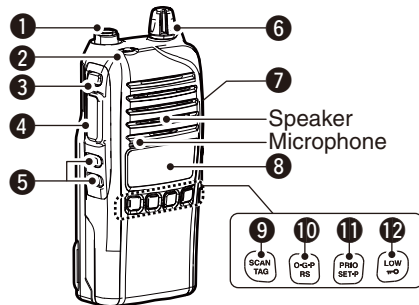

### ① ANTENNA CONNECTOR

Connects the supplied antenna.

### ② TOP KEY [TOP]

Toggles Normal (N), Function (F) and Set (S) modes.

#### In Normal mode

- ➔ Push to turn Function mode ON. ("F" is displayed)
- ➔ Push and hold for 2 seconds to enter set mode (p. 11).

#### In Function mode

- ➔ Push to return to Normal mode.
- ➔ When a receive channel is selected (once enabled), push and hold for 2 seconds to enter RX VFO (receive frequency select) mode. (p. 29)

/// **NOTE** : After 30 seconds in Function mode with no operation, unit will return to Normal mode.

### ③ SIDE1 KEY [Side1]

#### In Normal mode

- ➔ Push to toggle the monitor (open tone squelch) function ON or OFF. (p. 10)
- ➔ Push and hold for 2 seconds to activate the following functions in order:
  - Tone squelch (only receive calls with same tone squelch code). "T SQL" appears. (p. 21)
  - Pocket beep (informs that a call was missed). "T SQL 📞" appears. (p. 21)
  - No tone operation. "T SQL 📞" disappears.

#### In Function mode

- ➔ Push to enter squelch setting mode, then push [CH Up] or [CH Down] to set the squelch level. (p. 10)
- ➔ Push and hold for 2 seconds to turn the ATS (Automatic Transponder System) function ON or OFF. (p. 28)

### ④ PTT SWITCH [PTT] (p. 9)

- ➔ Push and hold to transmit. Release to receive.
- ➔ A PTT hold function is also available. See page 30 for more information.

### ⑤ CH UP/CH DOWN KEYS

### ⑥ VOLUME CONTROL

Rotate to turn power ON or OFF and set operating volume.

### ⑦ EXTERNAL SPEAKER JACK

Connect an optional speaker microphone. Ensure power is OFF before connecting external devices.

---

## 2 UNIT DESCRIPTION

### 8 LCD DISPLAY (p. 5)

### 9 SCAN/TAG KEY

#### In Normal mode

- Push to start or stop scanning. This is dependent on tagged channels. (p. 17)
- Push and hold for 2 seconds to set or clear displayed channel as tagged. (p. 17)

#### In Function mode

- Push to enter the Selcall code channel selection mode, when a CB channel is selected. (p. 24)
- Push and hold for 2 seconds to transmit to the Selcall code channel, when a CB channel is selected. (p. 25)

### 10 O.G.P/RS KEY

#### In Normal mode

- Push repeatedly to cycle through open, group and priority scan. (“OS”, “GS” or “PS” will be displayed.) (pp. 18, 19)
- Push and hold for 2 seconds to start/stop the repeater scan. (p. 20)

#### In Function mode

- When a CB channel is selected, push to toggle the quiet function ON or OFF. (p. 27)
- Push and hold for 2 seconds to display a history of received ID codes. (p. 26)

### 11 PRIO/SET.P KEY

#### In Normal mode



- Push to change the selected channel to the priority channel. (p. 10)
- Push and hold for 2 seconds to set the displayed channel as the priority channel. (pp. 10, 19)

#### In Function mode

- Push to transmit the smart-ring signal (in CTCSS mode). (p. 28)
- Push and hold for 2 seconds to clear the priority channel setting. (p. 10)

### 12 LOW/ KEY

#### In Normal mode

- Push to toggle the transmit output power level. (p. 9)
- Push and hold for 2 seconds to electronically lock all keys except [PTT], [Side1], [Top],  (while in Function mode only) and .
- Push and hold again for 2 seconds to unlock all keys.

#### In Function mode

- When a Repeater channel is selected, push to toggle between duplex (repeater access) and simplex (no repeater access) operation. This is dependent on default settings.
- Push and hold for 2 seconds to enter zone selection mode. (p. 8)

## ■ Display

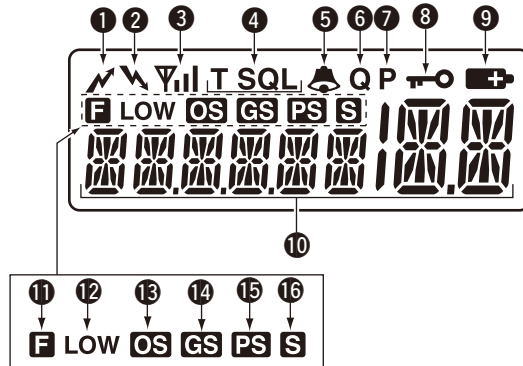

### 1 TRANSMIT INDICATOR

Appears when transmitting.

### 2 BUSY INDICATOR

Appears while the channel is busy.

### 3 SIGNAL STRENGTH INDICATOR

- ➔ Indicates relative signal strength level.
- ➔ Blinks when ATS is in use.

### 4 TONE INDICATORS (p. 23)

- ➔ “T” appears while the subaudible tone encoder is in use.
- ➔ “T SQL” appears while the tone squelch/DTCS squelch function is in use.

### 5 BELL INDICATOR

- ➔ Appears when the pocket beep function is in use. (p. 23)
- ➔ Blinks when the specified selcall or smart ring call is received. (pp. 26, 28)

### 6 QUIET INDICATOR

Appears when the quiet function is ON. (p. 27)

### 7 PRIORITY CHANNEL INDICATOR

Appears when the priority channel is set. (p. 10)

### 8 KEY LOCK INDICATOR

Appears when the keylock function is ON. (p. 8)

### 9 BATTERY INDICATOR

Appears or blinks when the battery capacity decreases to a specified level.

### 10 ALPHANUMERIC DISPLAY

Displays the operating channel number, channel name, set mode contents etc.

### 11 FUNCTION INDICATOR

Appears when the function mode is ON. This allows secondary functions to be accessed.

---

## 2 UNIT DESCRIPTION

### 12 LOW POWER INDICATOR

- ➔ Appears when low output power is selected, or the unit is operating in dry (alkaline) battery mode.
- ➔ When the battery power decreases below the specified level, the unit will switch to low power automatically.

### 13 OPEN SCAN INDICATOR

Appears when open scan is selected.

### 14 GROUP SCAN INDICATOR

Appears when group scan is selected.

### 15 PRIORITY SCAN INDICATOR

Appears when priority scan is selected.

### 16 SCAN CHANNEL INDICATOR

Appears when the selected channel is specified as a tagged channel.

---

### ✓ INFORMATION

“N/A” appears when the pushed key is not available.



## ■ Turning the Power ON

▨ Prior to using the transceiver for the first time, the battery pack must be fully charged for optimum life and operation.

- Rotate the [VOL] knob clockwise to turn the power ON.
- If the transceiver is programmed with a start-up password, this needs to be entered before operation can commence. To input the password, first refer to the table below.

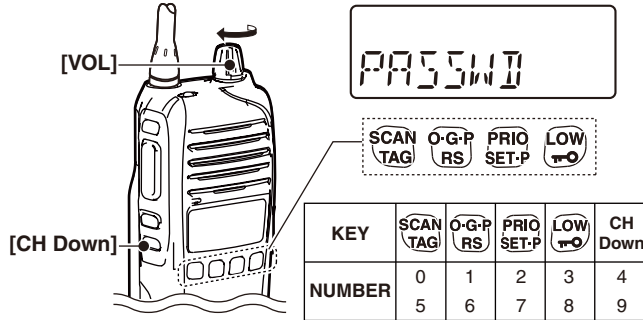

The password is made up of a four-digit code (e.g. 1234, 5420 etc). Push the corresponding buttons to enter your password. Please note that each key represents two digits, meaning that, for example, the passwords 3764 and 8769 are entered in exactly the same way (i.e. no multiple or extended pushing required). When entering the password, no information will be displayed on screen. If, after inputting four digits, the “PASSWD” does not disappear, the password entered is incorrect. To try again, turn the power OFF and ON again.

## ■ Battery type

The transceiver can be used with the supplied Li-ion battery pack or the optional battery case with third party AA batteries. In order to maximise the transceiver’s effectiveness, it is important that the transceiver is switched to the appropriate mode before operation.

### To do this:

- ① Ensure the transceiver power is OFF.
- ② While pushing and holding the [Top] and [PTT] buttons, rotate the volume knob to turn the power ON
  - The display will either show “dry” (AA battery case), or Li-ion. (battery pack)
  - At this stage, the [Top] and [PTT] buttons can be released.
- ③ If the mode is now correct, the transceiver is ready for operation. If the incorrect mode is selected, repeat the above process.

▨ **NOTE:** In ‘dry’ mode, the transceiver is preset to low output power. (1W)

---



## 3 BASIC OPERATION

### ■ Backlight



The transceiver features a backlit LCD display for low-light operation. The modes available for the backlight can be changed via the set mode.

- ① To enter set mode, push and hold [Top] for 2 seconds, then release.
- ② Push [Top] several times until “Light” appears.
- ③ Push [CH Up] or [CH Down] to set the backlight mode.
  - **ON** : Backlight is on continuously.
  - **A2** : Lights for 5 seconds when LCD indication is changed or any key except [PTT] is pushed.
  - **AT** : Lights for 5 seconds when a selcall signal is transmitted/received or any key except [PTT] is pushed.
  - **OF** : Backlight never lights.
- ④ To exit set mode, push and hold [Top] for 2 seconds, or turn transceiver OFF.

### ■ Keylock

This function electronically locks all keys except for [PTT], [Side 1], [Top],  (when in function mode only) and , to prevent accidental channel changing and function access.

#### To lock the keypad:

- ➔ Push and hold  for 2 seconds to toggle the lock function ON and OFF. “” is displayed when the keypad is locked.

### ■ Channel/Zone Selection

#### ◇ Channel Selection



Changing channels on a UHF CB is important to ensure that you can communicate with the intended person(s). The 80 channels available on the UHF CB band also help to allow clear, uninterrupted communication. The IC-41W can access all 80 channels on the UHF CB band, as well as designated repeater channels. It is also capable of storing a combination of up to 48 receive only and private channels. (dealer programmable)

➔ Push the [CH Up] and [CH Down] buttons to scroll through the available channels.

- It is also possible to push and hold these buttons for continuous scrolling.
- “CB-xx” appears when a CB channel is selected and RX-xx appears when an RX channel is selected. (where “xx” represents the channel number)

#### ◇ Zone Selection (available only when two or more zones are set)

A zone is a grouping of private channels, mainly used for commercial applications. It allows only certain groups or business departments to communicate within the allocated zone.

- ① Push [Top] to enter function mode, then push and hold  for 2 seconds to enter the zone selection mode.
- ② Push [CH Up] or [CH Down] to select the desired zone, then push  again to confirm.



#### NOTE:

- The selected channel is retained when the transceiver is turned off.
- The CB-05, CB-R5 and CB-35 channels are used for emergency use, and are required to be left open for this use only. The CB-22 and CB-23 channels are used for data transmission, meaning voice transmission is inhibited.

## ■ Receiving/Transmitting

**NOTE:** Transmitting without an antenna may damage the transceiver. See page 1 for more information.

### ◇ Receiving

- If “T SQL” or “T SQL - ① Select the desired operating channel.
- ② When receiving a signal, “

### ◇ Transmitting

- ① Wait for the channel to become clear to avoid interference.
- ② While pushing and holding [PTT], speak into the microphone at a normal voice level.
- ③ When transmitting, “

### Important:

- To maximise the clarity of the signal:
- Pause briefly after pushing [PTT]. This will ensure the first part of your message is heard.
  - Hold the microphone about 5 to 10 cm from your mouth.

- **Transmit inhibit function** – The transceiver will restrict transmission under the following conditions:
  - The channel is busy, or different CTCSS/DTCS code is received. (depending on the transmission lockout function setting)
  - The selected channel is a receive only channel. (e.g. CB22, CB23)
- **Power Output**
  - Depending on the setting, it may be useful to reduce/increase the power output of the transceiver. Simply push  to toggle between high (5W) and low (1W). “LOW” will be displayed when low output power is selected. Select low power to conserve battery power, or high power for longer distance communications.
- **Time-out/Penalty/Lockout Timer**
  - These functions limit transmission over the air and can be activated or modified via dealer programming.

---

## 3 BASIC OPERATION

### ■ Priority Channel

The priority channel allows the user to have quick access to a specific channel. Only one channel can be set as the Priority Channel. “P” appears when the Priority Channel is set.

#### ◇ To set the Priority Channel

- ① Select the desired channel using [CH Up] and [CH Down]
- ② Push and hold  $\overline{\text{PRIORITY SET.P}}$  for 2 seconds to set the current channel as the Priority Channel.

#### ◇ To switch to the Priority Channel

- ➔ Push  $\overline{\text{PRIORITY SET.P}}$  to switch from the current channel to the Priority Channel. “N/A” appears when there is no Priority Channel set.

#### ◇ To cancel the Priority Channel

- ➔ Push [Top] to enter the Function Mode, then push and hold  $\overline{\text{PRIORITY SET.P}}$  for 2 seconds to cancel the Priority Channel. “P” disappears.

### ■ Monitor

The monitor function opens the squelch or tone squelch, allowing weak signals to be received. This allows quick access to an open squelch setting, to allow weak transmissions to be received.

- ➔ To toggle the monitor function on or off, push [Side 1].
  - “” blinks when the monitor function is in use.

### ■ Squelch

In order to receive signals clearly, the squelch level can be adjusted to suit the operating environment. This eliminates background noise when there are no signals present. A higher setting is better for inner city or noisy areas, and lower setting is more beneficial in quiet, rural and country areas.

#### To adjust the squelch sensitivity:

- ① Push [Top] to enter second function mode, then push [Side 1] to enter the squelch setting mode.
- ② Push [CH Up] or [CH Down] to adjust the squelch level from 0 to 9. (0= lowest setting, 9= highest setting)
- ③ Push [Side 1] to exit the squelch setting mode.



The Set Mode allows the user to change various settings in the transceiver to suit their operating requirements. Available settings may differ, depending on the preprogramming of the optional CS-41S CLONING SOFTWARE. The Set Mode can be accessed by pushing and holding [Top] for 2 seconds. If no key is pushed for 30 seconds, the transceiver will return to the normal mode.

The following diagram shows the selection sequence of the Set Mode Functions:

### When in the Set Mode:

- ① Push [Top] to select the desired item.
- ② Push [CH Up] or [CH Down] to adjust the setting.
- ③ Push and hold [Top] for 2 seconds to exit the Set Mode, or simply turn OFF the transceiver.

**Please note** that the default factory setting omits both the squelch level and your own ID from the set mode sequence. These can be activated through the dealer programming software, if required. The squelch level can also be modified using the process described in section 5.

### ◆ Set mode construction

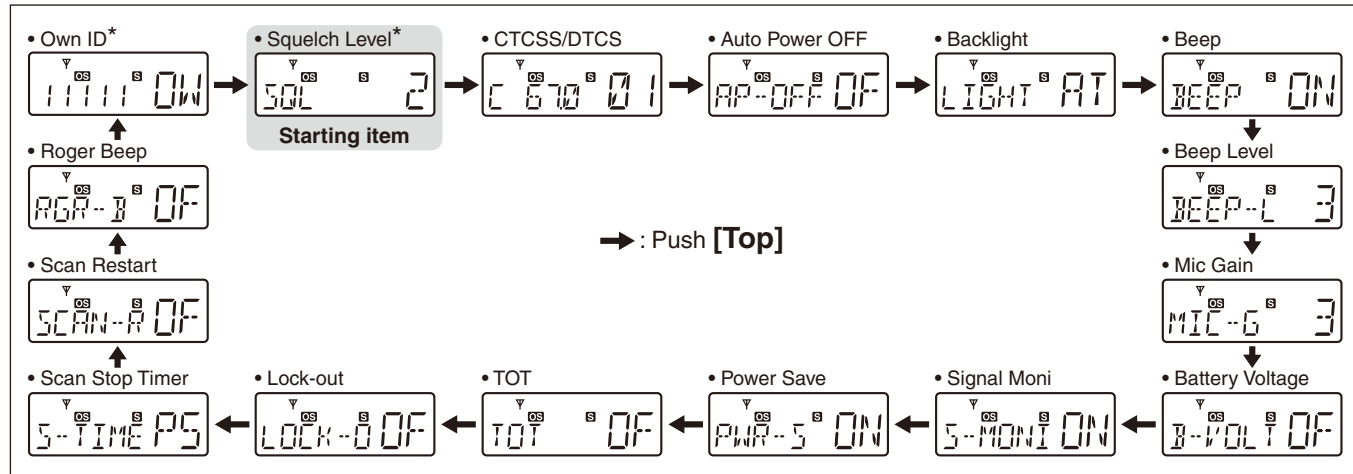

## 4 SET MODE

### ◇ Squelch

In order to receive signals clearly, the squelch level can be adjusted to suit the operating environment. This eliminates background noise when there are no signals present. A higher setting is better for inner city or noisy areas, and lower setting is more beneficial in quiet, rural and country areas. There are 10 available squelch levels. (0=lowest setting, 9=highest setting)



Squelch level 2 (default)

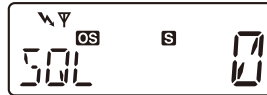

Squelch level 0 ("V" appears)

### ◇ CTCSS/DTCS

Select the desired CTCSS tone frequency or DTCS code. Pushing  $\left(\begin{smallmatrix} \text{SCAN} \\ \text{TAG} \end{smallmatrix}\right)$  toggles the CTCSS/DTCS setting mode. CTCSS/DTCS is explained further in page 21.

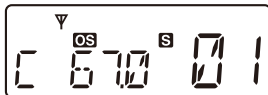

CTCSS tone frequency setting mode (default)

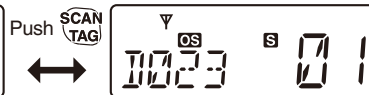

DTCS code setting mode

### ◇ Auto Power OFF

The transceiver can be set to automatically turn off after a set period of inactivity (i.e. no key has been pushed). This can be set anywhere from 0.5 to 4.0 hours, in 0.5 hour steps.



Auto power OFF is OFF (default)



2.0 hours setting

### ◇ Backlight

The transceiver features a backlit LCD display for low-light operation.

- ON : Backlight is on continuously.
- A2 (Auto2) : Lights for 5 seconds when LCD indication is changed or any key except [PTT] is pushed.
- AT (Auto) : Lights for 5 seconds when a selcall signal is transmitted/received or any key except [PTT] is pushed.
- OF (OFF) : No backlight available.

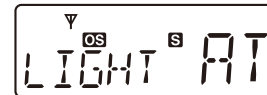

Backlight Auto (default)



Backlight ON

### ◇ Beep

By default, confirmation beep tones are turned on. This can be toggled ON or OFF by the set mode, for silent operation.



Beep tone ON (default)



Beep tone OFF

### ◇ Beep Level

The volume level of the key touch beep can be altered from 1 (softest) to 5 (loudest).

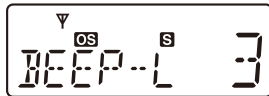

Beep level 3 (default)



Beep level 1

### ◇ Mic Gain

The sensitivity of the microphone can be changed from 1 (minimum sensitivity) to 5 (maximum sensitivity). With a higher sensitivity, the microphone will register softer voices, although, it may pick up more ambient noise.

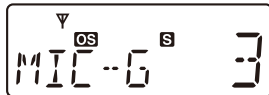

Mic gain level 3 (default)

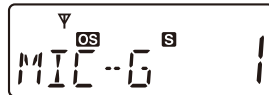

Mic gain level 1

### ◇ Battery Voltage

The transceiver can be set to display the remaining battery charge for a 2 second period after being turned ON.



Battery voltage  
OFF (default)



Battery voltage ON

### ◇ Signal Monitor

This function controls the mute condition during selcall code signal and roger beep emission. By default, it is turned ON.



Signal monitor ON (default)



Signal monitor OFF

### ◇ Power Save

The auto power save function works by deactivating the receiver circuit, which reduces battery consumption. If a signal is not received, or the unit is inactive for 5 seconds, the transceiver will enter power save mode.

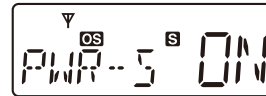

Power save ON (default)

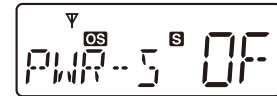

Power save OFF

## 4 SET MODE

### ◇ TOT (Time-Out Timer)

The time-out timer limits the length of one continuous transmission. This helps conserve battery charge in the event of accidental continuous transmission. By default, this is turned OFF.



TOT OFF (default)



TOT ON

### ◇ Lock-out

This allows the user to select the temporary transmission inhibit capability, preventing communication overlap, which can lead to missed or broken transmissions.

- RP (Repeater Lockout): Transmission is permitted only while receiving a matched CTCSS tone or when no signal is received.
- BU (Busy Lockout) : Transmission is inhibited while receiving a signal.
- OF (OFF) : No restrictions.

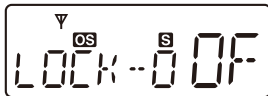

Lockout OFF (default)

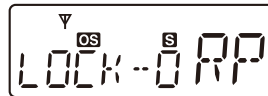

Repeater lockout setting

### ◇ Scan Resume Timer

The scan resume condition can be set as a pause (P5) or timer scan (15/10/5). When a signal disappears, scanning will resume after 5 seconds, regardless of the setting.

15/10/5 : Scan pauses for 15/10 or 5 seconds when a signal is detected, then resumes.

P5 : Scan pauses until the signal disappears, and then resumes after 5 seconds.

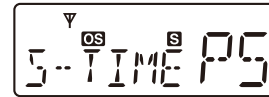

Scan resume timer  
P5 (default)



10 sec. setting

### ◇ Scan Restart

When in scan mode, the scan restart function resumes scanning 10 seconds after a transmission has been performed.

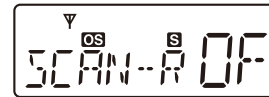

Scan restart timer  
OFF (default)



Scan restart timer ON

### ◇ Roger Beep

The roger beep emits a sound as acknowledgement that the transmission has ceased.



Roger beep OFF (default)

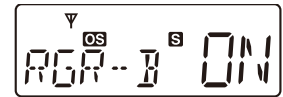

Roger beep ON

### ◇ Own ID

This function allows the user to edit their own ID (this function is inactive by default, and can be turned on via dealer programming). Own ID is useful in commercial applications to allow organisations to track where transmissions originate from.

#### To edit:

- ① When in set mode, and own ID has been selected, push and hold  for 2 seconds to enter the own ID edit mode.

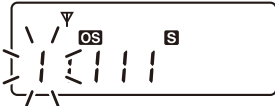

- ② Push [CH Up] and [Ch Down] until the selected integer is displayed on the blinking digit.

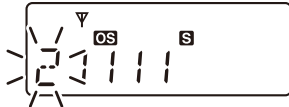

- ③ Push  to set the blinking digit and progress to the next.

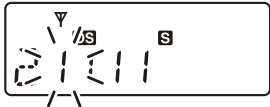

- ④ Repeat this until all digits have been set correctly, the push  once more to set the Own ID.



# 5

## REPEATER OPERATION

### ■ Repeater Operation

Repeaters extend the operational range of the transceiver by amplifying received signals. They are usually located on the top of hills or mountains, as the elevation increases their effectiveness, allowing the user to transmit and receive over greater distances. During standard operation, or simplex, transceivers transmit and receive on the same frequency. When operating in duplex mode (i.e. accessing a repeater), the transceiver will need to transmit and receive on different frequencies. The transceiver will automatically do this when one of the repeater channels is selected.

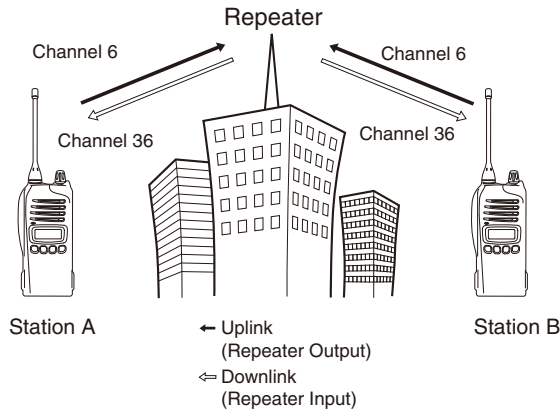

#### To access the repeater channels:

- Use the [CH Up] and [CH Down] keys to select a repeater channel.
- Use the transceiver as you normally would. (see page 9)

The transceiver can also search for accessible repeaters in the area by using the repeater scan function. More detail of this can be found in page 20.

Please note that the ACMA advises to avoid operation on locally used repeater input channels (CH 31–38 and CH 71–78) and locally used repeater output channels (CH1–8 and CH 41–48) unless long distance communication via the repeater facility is specifically required.

#### NOTE:

When a repeater channel is selected, the display will show “CB-R0X R1”, where “X” will change depending on the repeater channel selected.

The IC-41W has four scan types, a tag function and four resume conditions. Scanning allows the transceiver to automatically scroll through all or selected channels in order to find a transmission.

## ■ Scanning Preparation

The IC-41W scans all tagged channels and can be set for a pause or timer resume condition. These items must therefore be defined before starting a scan (except for the repeater search scan), and must be set for each scan type independently.

### ◇ Scan type selection

Push  (scan mode) several times to select the desired scan type.

- Open, group and priority scans are available (see below).

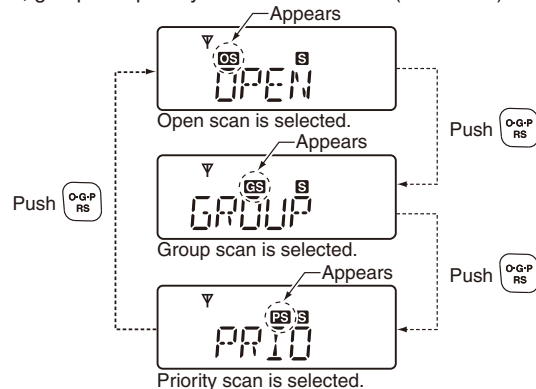

Setting channels as 'tag' channels allows them to be included in the scan function.

#### To set a tag channel:

- ① Select the desired scan type. (to the left)
- ② Select the desired channel. (use the [CH Up] and [CH Down] keys)
- ③ Push and hold  for 2 seconds to toggle the tag function ON or OFF. ("S" appears when the tag setting is on)

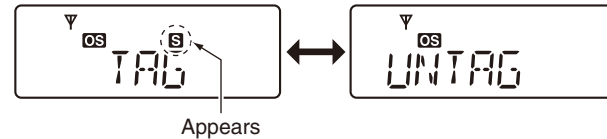

## 6 SCAN

### ◇ Scan Resume Condition

The scan resume condition can be set as a pause (P5) or timer scan (15/10/5). When a signal disappears, scanning will resume after 5 seconds, regardless of the setting.

- ① Push and hold [Top] for 2 seconds to enter set mode.
- ② Push [Top] several times until 'S-TIME' is displayed.
- ③ Push [CH Up] or [CH Down] to select the scan resume time.  
15/10/5 : Scan pauses for 15/10 or 5 seconds when a signal is detected, then resumes.  
P5 : Scan pauses until the signal disappears, and then resumes after 5 seconds.
- ④ Rotate [VOL] to turn power OFF, or push and hold [Top] for 2 seconds to exit set mode.



Scan stop timer  
P5 (default)



10 sec. setting

### ■ Open Scan

The open scan function scans for transmitted signals, making it easier to locate new stations for contact or listening purposes.

#### To start an open scan:

- ① Push  $\left(\begin{smallmatrix} \text{O-G-P} \\ \text{RS} \end{smallmatrix}\right)$  a few times until open scan is selected.
  - "OS" is displayed.

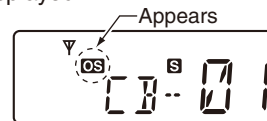

Open scan is selected.

- ② Push  $\left(\begin{smallmatrix} \text{O-G-P} \\ \text{RS} \end{smallmatrix}\right)$  to start the scan.

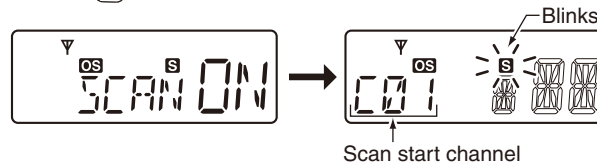

- ③ When a signal is received, the scan will pause and resume according to the selected scan resume condition.
- ④ Push  $\left(\begin{smallmatrix} \text{SCAN} \\ \text{TAG} \end{smallmatrix}\right)$  to cancel the scan.



## ■ Group and Priority Scan

Group and priority scans repeatedly watch a priority channel while scanning the specified tag channels. This is useful when waiting for a call on the priority channel. Group and priority scans behave differently when transmitting. Group scan allows the user to transmit on a busy or priority channel. Priority scan will only allow transmission on a priority channel. (or the channel scanning starts ON, if no priority channel is set)

### To initiate a group or priority scan:

- Push until group or priority scan is selected.
  - “GS” appears when group scan is selected, and “PS” appears when priority scan is selected.

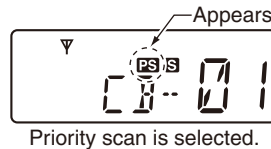
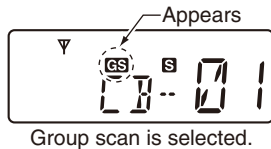

- Set the priority channel by holding down for 2 seconds while on the desired channel.
  - To cancel the priority channel, push [Top] to enter second function mode, then push and hold to remove the priority setting.



- Push to start the scan.

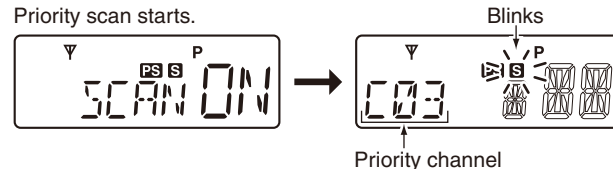
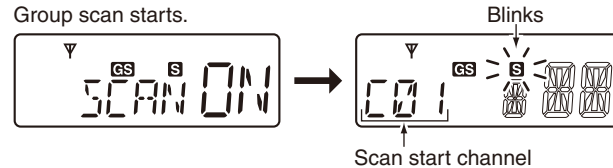

- When receiving a signal, the scan will pause and resume according to the selected scan resume condition.
- Push to cancel the scan.

## 6 SCAN

### ■ Repeater

The repeater search scan is not only used to search for a signal on the repeater channels, but also to access a repeater by transmitting automatically in sequence. The repeater search function searches available repeaters in the area. The repeater scan detects signals on repeater channels. When the repeater is not busy, it will be available for use. The repeater scan will stop should any activity be detected (The scan is cancelled when receiving a signal, such as stations communicating in simplex operation on a repeater output channel).

- Excludes emergency repeater channel CB-R5.

#### To start the repeater scan:

- ① Select the desired repeater output channel and push and hold  $\text{P-G-P}$  for 2 seconds to start the repeater scan.

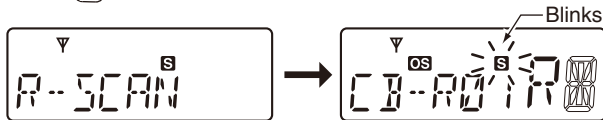

- ② When a signal is received on the repeater channel, scanning will stop. (during the second cycle scanning the repeater channels, three high beeps will sound when a signal is received, and three low beeps will sound when no signal is received)
- ③ Push  $\text{P-G-P}$  to cancel the scan manually. (when transmitting, the repeater scan cannot be cancelled)

#### ◇ Repeater search scan flow

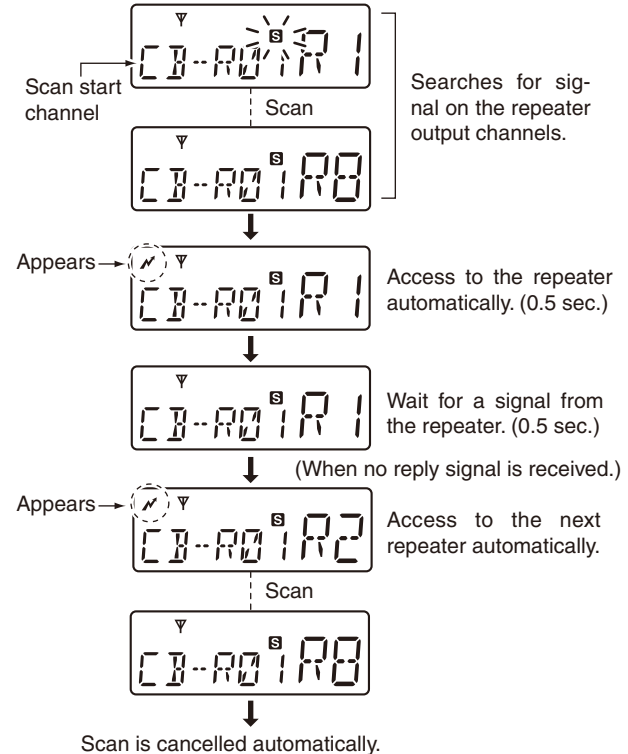

**NOTE:** Excludes Emergency Repeater 'CB-R5.'

Tone squelch allows the user to only hear transmissions with others who have set the same code on their transceiver. This is useful in business applications or in situations where small children are present, so that profanities and nonsense transmissions cannot be heard. Please note that this is not a privacy function, as those without tone squelch activated will still hear your transmission. Please also be aware that transmissions that cannot be heard will cause the channel to become busy. The IC-41W is equipped with both CTCSS (Continuous Tone-Coded Squelch System) and DTCS (Digital Tone Coded Squelch). Both methods work by producing a sub-audible tone or code which is either accepted or rejected by the receiving transceiver, depending on whether the tone matches its code. If accepted, the squelch will open, allowing the transmission to be heard. If rejected, the squelch will remain closed and the transmission will be muted.

In addition to standard tone squelch, a pocket beep function is also available. This function uses CTCSS or DTCS for calling and can be used in a similar fashion to a pager. It informs the user that someone has called while away from the transceiver.

## ◇ Setting Up a CTCSS/DTCS Code

- ① Select the desired channel (excluding channel 5 or 35) using the [CH Up] and [CH Down] keys.
- ② Push and hold [Top] for 2 seconds to enter set mode.
- ③ Repeatedly push [Top] while in set mode until "C" or "D," followed by a number appears on the display.
- ④ Push  $\frac{\text{SCAN}}{\text{TAG}}$  to toggle between CTCSS set mode and DTCS set mode.
- ⑤ Repeatedly push [CH Up] and [CH Down] to set the desired CTCSS tone frequency/DTCS code.

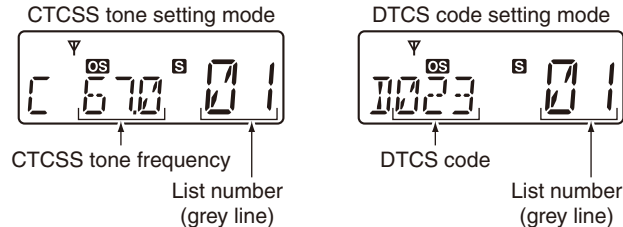

- ⑥ Rotate [VOL] to turn the power OFF, or push and hold [Top] for 2 seconds to exit set mode.

# 7 TONE SQUELCH

## • Available CTCSS tone frequency list (Hz)

No.	Freq.	No.	Freq.	No.	Freq.	No.	Freq.	No.	Freq.
01	67.0	12	94.8	23	136.5	34	177.3	45	218.1
02	69.3	13	97.4	24	141.3	35	179.9	46	225.7
03	71.0	14	100.0	25	146.2	36	183.5	47	229.1
04	71.9	15	103.5	26	151.4	37	186.2	48	233.6
05	74.4	16	107.2	27	156.7	38	189.9	49	241.8
06	77.0	17	110.9	28	159.8	39	192.8	50	250.3
07	79.7	18	114.8	29	162.2	40	196.6	51	254.1
08	82.5	19	118.8	30	165.5	41	199.5		
09	85.4	20	123.0	31	167.9	42	203.5		
10	88.5	21	127.3	32	171.3	43	206.5		
11	91.5	22	131.8	33	173.8	44	210.7		



**NOTE:** The transceiver has 51 tone frequencies and consequently their spacing is narrow compared with units having 38 tones. Therefore, some tone frequencies may receive interference from adjacent tone frequencies.

## • Available DTCS code list

No.	Code	No.	Code	No.	Code	No.	Code	No.	Code
01	023	22	131	43	251	64	371	85	532
02	025	23	132	44	252	65	411	86	546
03	026	24	134	45	255	66	412	87	565
04	031	25	143	46	261	67	413	88	606
05	032	26	145	47	263	68	423	89	612
06	036	27	152	48	265	69	431	90	624
07	043	28	155	49	266	70	432	91	627
08	047	29	156	50	271	71	445	92	631
09	051	30	162	51	274	72	446	93	632
10	053	31	165	52	306	73	452	94	654
11	054	32	172	53	311	74	454	95	662
12	065	33	174	54	315	75	455	96	664
13	071	34	205	55	325	76	462	97	703
14	072	35	212	56	331	77	464	98	712
15	073	36	223	57	332	78	465	99	723
16	074	37	225	58	343	79	466	100	731
17	114	38	226	59	346	80	503	101	732
18	115	39	243	60	351	81	506	102	734
19	116	40	244	61	356	82	516	103	743
20	122	41	245	62	364	83	523	104	754
21	125	42	246	63	365	84	526		

### ◇ Turning the tone squelch operation ON or OFF

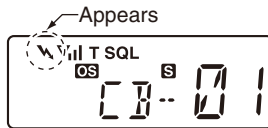
- ① Select the desired channel (excluding channel 5 or 35) using the [CH Up] and [CH Down] keys.
- ② Set the desired CTCSS tone frequency/DTCS code in set mode. (see page 12)
- ③ Push and hold [Side 1] for 2 seconds several times until “T SQL” appears. Each 2 second push will scroll through, “T SQL 📢” (pocket beep) and blank (OFF).
- ④ When the received signal includes a matching tone or code, the squelch opens and the signal can be heard. When the received signal is not matched, the squelch will not open, but “📢” will appear to show the channel is busy. To open the squelch manually, push [Side 1].



- ⑤ The transceiver can now be operated as per normal.
- ⑥ To cancel the tone squelch operation, push and hold [Side1] for 2 seconds several times until both “T SQL,” “T SQL 📢” disappear.

**NOTE:** CTCSS tone frequency/DTCS code and tone squelch ON/OFF settings are automatically stored in memory channels for easy recall.

### ◇ Setting up and using the pocket Beep

- ① Select the desired channel (excluding channel 5 or 35) using the [CH Up] and [CH Down] keys.
- ② Set the desired CTCSS tone frequency/DTCS code in set mode. (see previous section)
- ③ Push and hold [Side 1] for 2 seconds several times until “T SQL 📢” appears. Each 2 second push will scroll through “T SQL,” “T SQL 📢” (pocket beep) and blank (OFF).
- ④ When the received signal includes a matching tone or code, the transceiver will emit a beep every 10 seconds, and “📢” will blink.

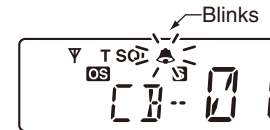



- ⑤ Push [PTT] to answer and stop the alert. The transceiver will automatically switch to tone squelch operation. (“T SQL” will be displayed)

# 8

## SELCALL (Selective Calling)

In addition to tone squelch operation for silent stand-by, Sel-Call operation is available. In tone squelch operation, there are 155 tone/code options when making a call. SelCall offers a much more versatile 100,000 options when using 5-tone. Other options available in SelCall are the ability to call another unit or group operating on the same channel, as well as station code/name information, status messages, answer back functionality and auto scan start. These, and many more can be set up via dealer programming.

**NOTE:** Channels 5 and 35 are used for emergency and channels 22 and 23 are used for data channels, meaning SelCall is not available on these channels. SelCall transmission is restricted to a total of 3 seconds. If trying to transmit longer than 3 seconds, "N/A" is displayed (when  is pushed) or an error beep is emitted. (when  is pushed)

### ■ Calling

#### ◇ TX Code Channel Selection

"" allows the user to change the TX code channel with [CH Up] or [CH Down]. TX code refers to the transmitting Sel-call mode. A maximum of 32 TX code channels can be pre-programmed into the transceiver using the optional CS-41S CLONING SOFTWARE.

#### ◇ To select a TX code channel

- ① Select the desired CB channel (CB-XX) except channels 5 and 35.
- ② Push [Top] to enter function mode, then push  to enter the TX code channel selection mode. (the code channel name is displayed instead of the code if it has been programmed via the CS-41S CLONING SOFTWARE)

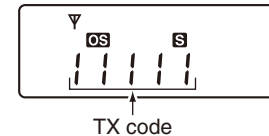

- ③ Push [CH Up] or [CH Down] to select the desired TX code channel.
- ④ Push [PTT] to transmit the selected TX code channel, or push  to set the selected TX code channel and return to the stand-by mode.

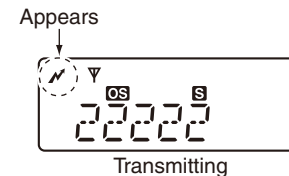

#### TIP:

All 32 TX code channel names can be assigned via the CS-41S CLONING SOFTWARE. This allows the user to easily select the channel and find other users, etc.

◇ TX code number edit

“SCAN TAG” enables the user to change the TX code digits contained in the TX code channel. The group call function works by allowing the user to edit a special ‘group code’ into the last 2 digits of the SelCall ID code.

**To edit a TX code:**

- ① Select the desired CB channel (CB-XX) except channels 5 and 35.
- ② Push [Top] to enter function mode, then push “SCAN TAG” to enter the TX code channel selection mode. If desired, push [CH Up] or [CH Down] to select the required TX code channel.
- ③ Push and hold “SCAN TAG” for 2 seconds again to enter the TX code edit mode.

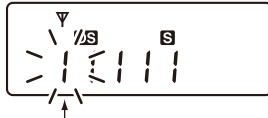

The editable digit starts blinking

- ④ Push “SCAN TAG” to select the desired digit to be edited.
- ⑤ Push [CH Up] or [CH Down] to set the desired code. Select ‘\*’ when group code is set.
- ⑥ Push “SCAN TAG” to set the digit and move to the next editable digit.



- ⑦ Repeat step ⑤ and ⑥ to input all digits.
- ⑧ After setting the final digit, push “SCAN TAG” to set the code and return to the TX code channel selection mode.
- ⑨ Push [PTT] to transmit the selected TX code channel, or push “SCAN TAG” to set the selected TX code channel and return to the stand-by mode.

Appears

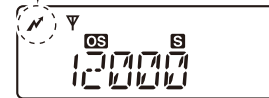

Transmitting

⚡ **NOTE:** the allowed editable digits can only be set via the CS-41S CLONING SOFTWARE. (optional)

**To transmit an individual call:**

- ➔ Push [Top] to enter function mode, then push and hold “SCAN TAG” for 2 seconds to transmit.

Appears



Transmitting

## 8 SELCALL (Selective Calling)

### ■ Receiving

#### ◇ Receiving an individual call (default setting)



- “PiRo” beeps sound.
- The received code channel name/number is displayed
- “🔔” and the displayed channel info blink, and Selcall mute is released when quiet mode is activated.
- While pushing and holding [PTT], speak into the microphone at a normal voice level.



#### NOTE:

- When the ID decode function is activated, the received ID code is displayed instead of the channel name, and memorised by the transceiver. The ID decode function can be activated via the CS-41S CLONING SOFTWARE.
- RX code means the receiving SelCall made. A maximum of 8 RX code channels can be pre-programmed into the transceiver using the optional CS-41S CLONING SOFTWARE.
- Various settings and conditions can be set for when an individual call is received via the optional CS-41S CLONING SOFTWARE. See the help file for more details.

#### ◇ Recalling a memorised receive selcall code

- ① Push [Top] to enter the function mode, then push and hold  for 2 seconds to display the memorised RX code.
- ② Push [CH Up] or [CH Down] to select the desired RX code.
- ③ Push [Top] to enter the function mode, then push and hold  for 2 seconds to transmit the code to the selected channel.

**NOTE:** Up to 8 receive code channels, and the receive condition, can be programmed via the CS-41S cloning software. Consult the CS-41S help file for more information.

#### ◇ When receiving a group call:

- “PiPi” tone sounds.
- “🔔” and “GROUP” blink, and Selcall mute is released when quiet mode is activated.
- While pushing and holding [PTT], speak into the microphone at a normal voice level.



- The group receive condition can be set via the CS-41S CLONING SOFTWARE. Consult the CS-41S help file for more information.



## ■ Quiet Mode

When quiet mode is turned ON, selcall mute is activated and allows silent operation until a selcall code is received. Push [Top] to enter function mode, then push  $\text{G+RS}$  to toggle quiet mode ON or OFF. ("Q" appears when quiet mode is in use)

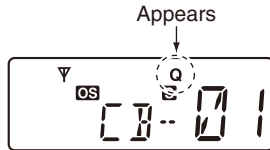

### ◇ To monitor the channel:

Push [Side 1] to release the mute. (audio is emitted)

- "W" blinks when the monitor function is in use.

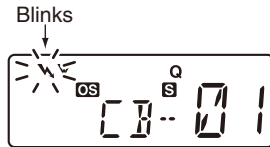

### ◇ To enable selcall mute:

When "W" blinks, push [Side 1] to mute the channel.

- "W" disappears.

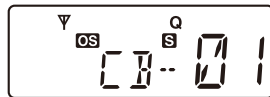

**NOTE:** the unmute condition may automatically revert to mute after a specified time, depending on the pre-settings.

## ■ Stun

- When a specified ID, set as a kill ID, is received, the stun function is activated (PC programming is required). This is designed to disable the transceiver for security purposes.
- When a killer ID is received, the transceiver switches to the "password required" condition. Entering the correct password via the keypad is necessary to operate the transceiver again. The required password is set via PC programming.

### ◆ Smart Ring/ATS

These functions have an answer back feature and allow confirmation if a call has reached the receiving party, even if the operator is temporarily away from the transceiver. These functions also allow the user to determine if another compatible Icom unit is in range, which is useful in convoy situations where groups may be separated. Smart ring is a manual confirmation, while ATS is automatic.

#### To set the smart ring function:

- ① Set the same CTCSS tone frequency on all transceivers in the group and turn the tone squelch ON. (see page 21)
- ② Push [Top] to enter function mode, then push **PRIOR SET.P** to send the smart-ring call.
  - “**N**” appears.
  - When a member of the group answers the call, “**A**” and “**FOUND**” blink.
  - When an answer isn’t received, the transceiver emits short failure beep tones and “**FAILD**” appears.

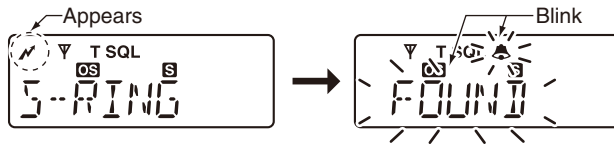

- ③ Push [PTT] to answer and to stop the display blinking.

**NOTE:** The smart ring function is only available when the called station has the same CTCSS tone frequency and operating channel as the user.

**NOTE:** The smart ring setting is for the calling station only. A called party automatically sends an answer back without any pre-settings. All IC-41W units operating on the same operating channel will answer back to the call in the surrounding communication area. When an RX channel is selected, “N/A” appears.

#### To set the ATS function:

- ① Push [Top] to enter function mode, then push and hold [Side 1] for 2 seconds to turn the ATS function ON.
  - When an RX channel is selected, an error beep is emitted
  - The transceiver will send a searching signal every 60 seconds automatically.
  - “**N**” appears and “**V**” starts blinking on the display when the function is activated.
  - When the transceiver receives an answer back signal, “**V**” stays on the display until the next search transmit.
  - If no reply is received, “**V**” blinks until the next search transmit.

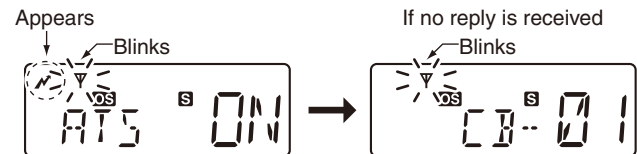



- ② Push [Top] to enter function mode, then push and hold [Side 1] for 2 seconds to turn the ATS function OFF.

### ◇ RX Frequency

The frequency of the RX channels can be re-programmed within the 450–520 MHz frequency range, to allow the transceiver to listen to communications outside the standard CB range. Please note that it is not possible to transmit on these channels.

As standard, the RX channels will not appear when scrolling through the list with [CH Up] and [CH Down]. In order to do so, the RX channels will need to be enabled.

#### To enable individual receive channels:

- While pushing and holding  and , turn the transceiver ON to enter the receive channel enable mode.
- Select the desired channel with [CH Up] and [CH Down], then push  to either set the channel as enabled or inhibited.



“Inhibit” setting



“Enable” setting

- Turn the power OFF, then ON. (The enabled receive channels will now appear when scrolling through the channels)

#### To program the RX frequencies:

- Select the desired RX channel (RX-XX), once enabled.
- Push [Top] to enter function mode, then push and hold [Top] for 2 seconds to enter the RX VFO mode.
- Push  to toggle between wide and narrow bandwidth.

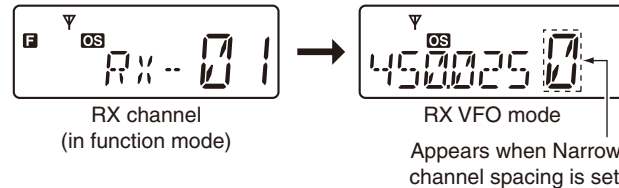

- Push [CH Up] and [CH Down] several times to select the desired frequency. The frequency changes according to the wide/narrow setting.

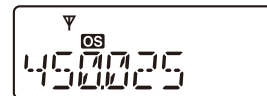

Wide channel spacing  
(25 kHz steps)

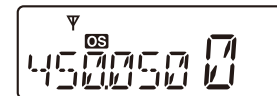

Narrow channel spacing  
(12.5 kHz steps)

- Push  to select the desired digit to be altered.



☞ Continued on the next page.

## 9 OTHER FUNCTIONS

### ◇ RX Frequency

To program the RX frequencies: (Continued)

- ⑥ Edit the desired digit with [CH Up] and [CH Down].

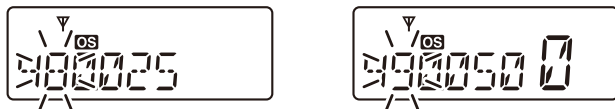

- ⑦ Push  $\overline{\text{SCAN TAG}}$  to set the digit and move to the next editable digit.

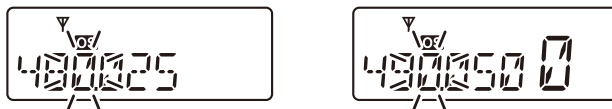

- ⑧ Repeat steps ⑥ and ⑦ to input the desired frequency.



- ⑨ Push and hold [Top] for 2 seconds to return to normal operation. The RX frequency is now memorised.



### ◇ PTT Hold

The PTT switch can be operated as a one touch PTT switch (each push toggles between transmit/receive). Using this function makes it possible to transmit without holding down the PTT switch. To prevent accidental continuous transmission with this function, the time-out timer function is automatically set. See page 9 for details.

- ① Turn power OFF
- ② While pushing and holding [PTT], turn power ON to turn the PTT hold function ON. (P-HOLD ON is displayed momentarily)



- ③ Push [PTT] to transmit, and push once again to return to receive/standby. ("N" appears while transmitting)
- ④ Repeat steps ① and ② to turn PTT hold OFF.

**NOTE:** The PTT hold function can only be used with the PTT switch on the transceiver. By attaching an optional microphone, the PTT hold functionality will be lost, as the PTT switch on the microphone must be used.

## ■ Caution

Misuse of Lithium-ion batteries may result in the following hazards: smoke, fire, or the battery may rupture. Misuse can also cause damage to the battery or degradation of battery performance.

⚠ **DANGER!** Use and charge only specified Icom battery packs with Icom radios or Icom charger. Only Icom battery packs are tested and approved for use and charge with Icom radios or Icom charger. Using third-party or counterfeit battery packs or charger may cause smoke, fire, or cause the battery to burst.

### Battery caution

⚠ **DANGER! DO NOT** hammer or otherwise impact the battery. Do not use the battery if it has been severely impacted or dropped, or if the battery has been subjected to heavy pressure. Battery damage may not be visible on the outside of the case. Even if the surface of the battery does not show cracks or any other damage, the cells inside the battery may rupture or catch fire.

⚠ **DANGER! NEVER** use or leave battery packs in areas with temperatures above +60°C. High temperature buildup in the battery, such as could occur near fires or stoves, inside a sun heated car, or in direct sunlight may cause the battery to rupture or catch fire. Excessive temperatures may also degrade battery performance or shorten battery life.

⚠ **DANGER! DO NOT** expose the battery to rain, snow, seawater, or any other liquids. Never charge or use a wet battery. If the battery gets wet, be sure to wipe it dry before using.

⚠ **DANGER! NEVER** incinerate used battery packs since internal battery gas may cause them to rupture, or may cause an explosion.

⚠ **DANGER! NEVER** solder the battery terminals or NEVER modify the battery pack. This may cause heat generation, and the battery may rupture, emit smoke or catch fire.

⚠ **DANGER!** Use the battery only with the transceiver for which it is specified. Never use a battery with any other equipment, or for any purpose that is not specified in this instruction manual.

⚠ **DANGER!** If fluid from inside the battery gets in your eyes, blindness can result. Rinse your eyes with clean water, without rubbing them, and see a doctor immediately.

---

## 10 BATTERY CHARGING

⚠ **WARNING!** Immediately stop using the battery if it emits an abnormal odor, heats up, or is discolored or deformed. If any of these conditions occur, contact your Icom dealer or distributor.

⚠ **WARNING!** Immediately wash, using clean water, any part of the body that comes into contact with fluid from inside the battery.

⚠ **WARNING! NEVER** put the battery in a microwave oven, high-pressure container, or in an induction heating cooker. This could cause a fire, overheating, or cause the battery to rupture.

**CAUTION:** Always use the battery within the specified temperature range,  $-20^{\circ}\text{C}$  to  $+60^{\circ}\text{C}$ . Using the battery out of its specified temperature range will reduce the battery's performance and battery life.

**CAUTION:** Shorter battery life could occur if the battery is left fully charged, completely discharged, or in an excessive temperature environment (above  $+50^{\circ}\text{C}$ ) for an extended period of time. If the battery must be left unused for a long time, it must be detached from the radio after discharging. You may use the battery until the remaining capacity is about half, then keep it safely in a cool dry place with the temperature range as below:

– $20^{\circ}\text{C}$  to  $+50^{\circ}\text{C}$  (within a month)

– $20^{\circ}\text{C}$  to  $+35^{\circ}\text{C}$  (within three months)

### ◇ Charging caution

⚠ **DANGER! NEVER** charge the battery pack in areas with extremely high temperatures, such as near fires or stoves, inside a sun heated car, or in direct sunlight. In such environments, the safety/protection circuit in the battery will activate, causing the battery to stop charging.

⚠ **WARNING! NEVER** charge or leave the battery in the battery charger beyond the specified time for charging. If the battery is not completely charged by the specified time, stop charging and remove the battery from the battery charger. Continuing to charge the battery beyond the specified time limit may cause a fire, overheating, or the battery may rupture.

⚠ **WARNING! NEVER** insert the transceiver (battery attached to the transceiver) into the charger if it is wet or soiled. This could corrode the battery charger terminals or damage the charger. The charger is not waterproof.

**CAUTION: NEVER** charge the battery outside of the specified temperature range: BC-160 and BC-171 ( $0^{\circ}\text{C}$  to  $+45^{\circ}\text{C}$ ;). BC-119N and BC121N ( $+10^{\circ}\text{C}$  to  $+40^{\circ}\text{C}$ ;). Icom recommends charging the battery at  $+20^{\circ}\text{C}$ . The battery may heat up or rupture if charged out of the specified temperature range. Additionally, battery performance or battery life may be reduced.

## ■ Rapid charging with the BC-160

The BC-160 provides rapid charging of the Li-ion battery packs.

Charging period: Approximately 3 hours.

The following items are additionally required:

- An AC adapter or the DC power cable (OPC-515L/CP-23L)

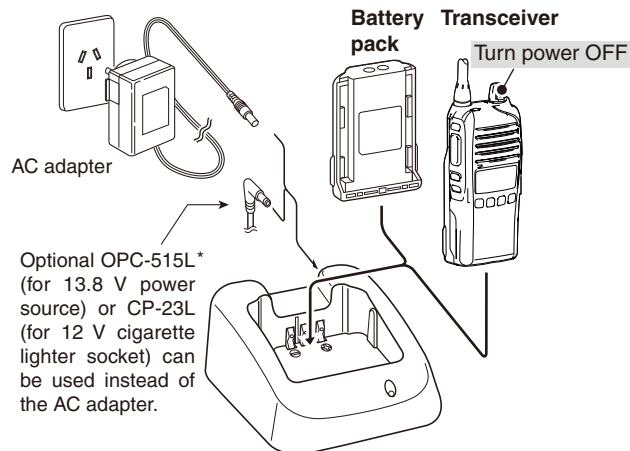

**\*CAUTION: NEVER** connect the OPC-515L to a power source using reverse polarity. This will ruin the battery charger.

White line: ⊕ Black line: ⊖

## ■ Optional battery chargers

### ◇ AD-106 installation

The AD-106 CHARGER ADAPTER must be installed into the BC-119N or BC-121N before battery charging.

- ① Connect the AD-106 CHARGER ADAPTER and the BC-119N/BC-121N.
- ② Install the AD-106 into the holder space of the BC-119N or BC-121N with the supplied screws.

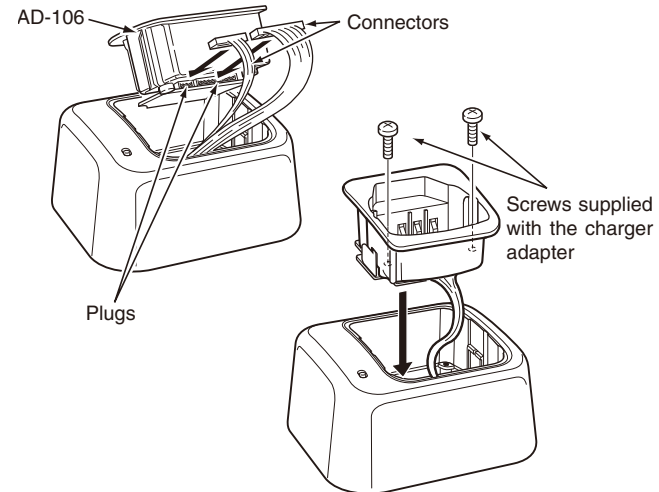

## 10 BATTERY CHARGING

### ◆ Rapid charging with the BC-119N+AD-106

The optional BC-119N provides rapid charging of the Li-ion battery pack.

Charging period: Approximately 3 hours.

The following items are additionally required.

- AD-106 CHARGER ADAPTER (purchase separately)
- An AC adapter or the DC power cable (OPC-515L/CP-23L).

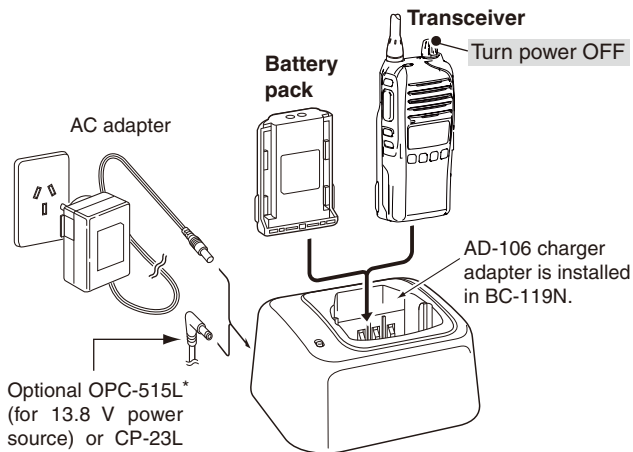

Optional OPC-515L\* (for 13.8 V power source) or CP-23L (for 12 V cigarette lighter socket) can be used instead of the AC adapter.

/// \*CAUTION: NEVER connect the OPC-515L to a power source using reverse polarity. This will ruin the battery charger.  
 /// White line : ⊕ Black line : ⊖

### ◆ Rapid charging with the BC-121N+AD-106

The optional BC-121N allows up to 6 battery packs to be charged simultaneously.

Charging period: Approximately 3 hours.

The following items are additionally required.

- Six AD-106 charger adapters
- An AC adapter (BC-157S) or the DC power cable (OPC-656)

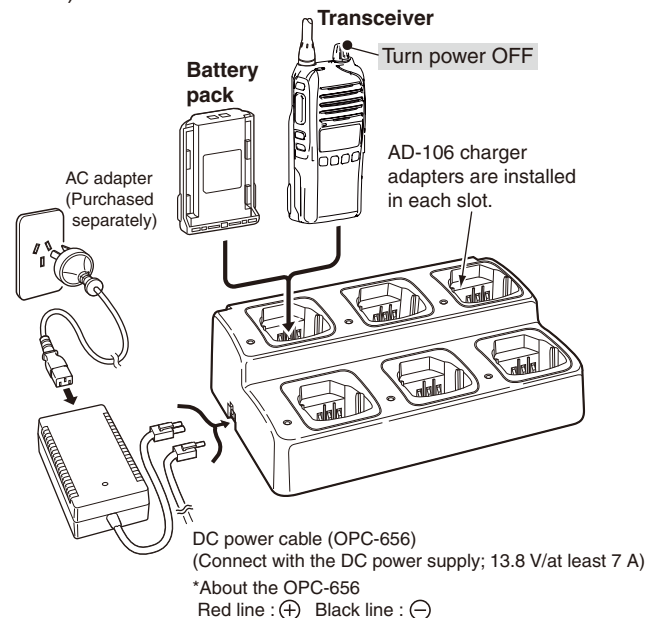



**IMPORTANT: Battery charging caution**

Ensure the guide tabs on the battery pack are correctly aligned with the guide rails inside the charger adapter.  
(This illustration is described with the BC-160)

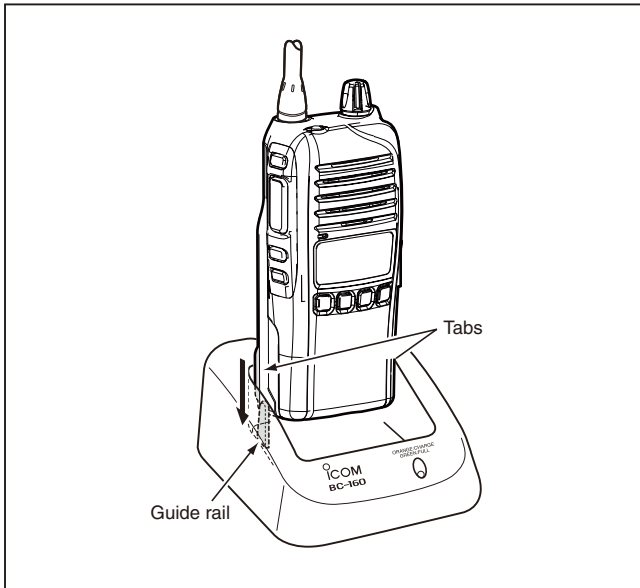

# 11 OPTIONS

## ■ MB-93 contents

- |                   | Qty. |
|-------------------|------|
| ① Belt clip ..... | 1    |
| ② Base clip ..... | 1    |

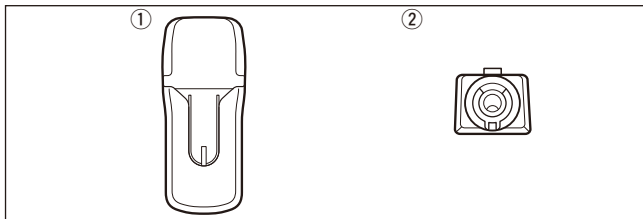

## ■ Attaching

- ① Release the battery pack if it is attached. (p. 1)
- ② Slide the base clip in the direction of the arrow until the base clip is locked and makes a 'click' sound.

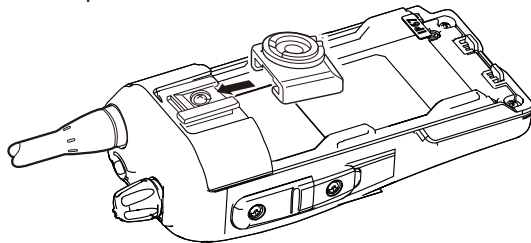

- ③ Attach the battery pack. (p. 1)

- ④ Clip the belt clip to a part of your belt. And insert the transceiver into the belt clip until the base clip inserted fully into the groove.

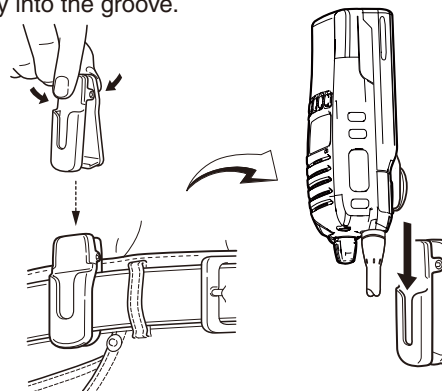

- ⑤ Once the transceiver is locked in place, it swivels as illustrated below.

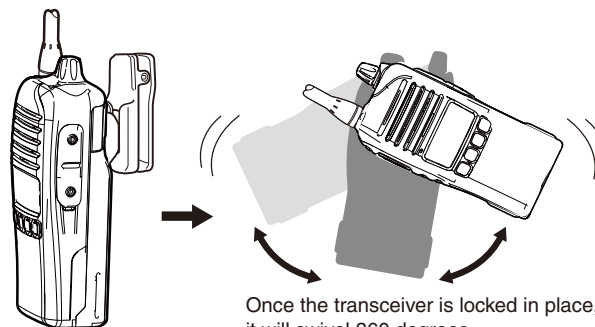

Once the transceiver is locked in place, it will swivel 360 degrees.

## ■ Detaching

- ① Turn the transceiver upside down in the direction of the arrow and pull out from the belt clip.

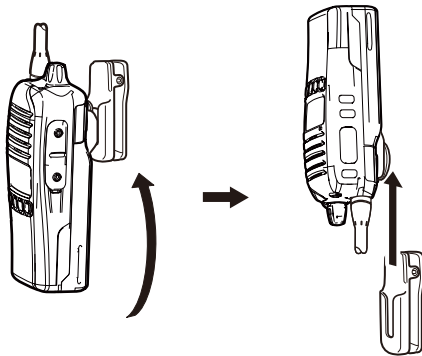

- ② Release the battery pack if it is attached. (p. 1)
- ③ Pinch the clip (①), and slide the base clip in the direction of the arrow (②).

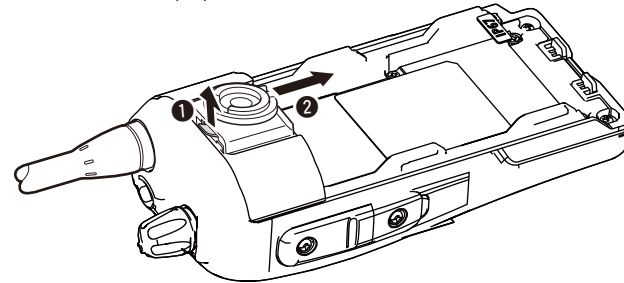

**CAUTION:**  
**HOLD THE TRANSCEIVER TIGHTLY, WHEN HANGING OR DETACHING THE TRANSCEIVER FROM THE BELT CLIP.**  
 Otherwise the transceiver may not be attached to the holder or swivel properly if the transceiver is accidentally dropped and the base clip is scratched or damaged.

# 11 OPTIONS

## ■ Optional HM-168LWP description

### Alligator type clip

To attach the speaker-mic.  
to your shirt or collar, etc.

### PTT switch

Transmits while pushed  
Receives while released

### Microphone

### Speaker

Turn the transceiver power  
OFF when connecting the  
HM-168LWP.

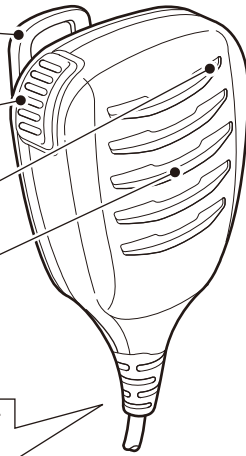

**NEVER** immerse the connector in water. If the connector becomes wet, be sure to dry it **BEFORE** attaching it to the transceiver.

**NOTE:** The microphone is located as shown in the diagram above. To maximize the readability of your transmitted signal (voice), hold the microphone approximately 5 to 10 cm from your mouth, and speak in a normal voice level.

## ■ Attachment

Attach the connector of the speaker-microphone into the [SP MIC] jack on the transceiver and tighten the screws with fingers.

**NOTE:** Use only your fingers instead of tools to tighten the screws.

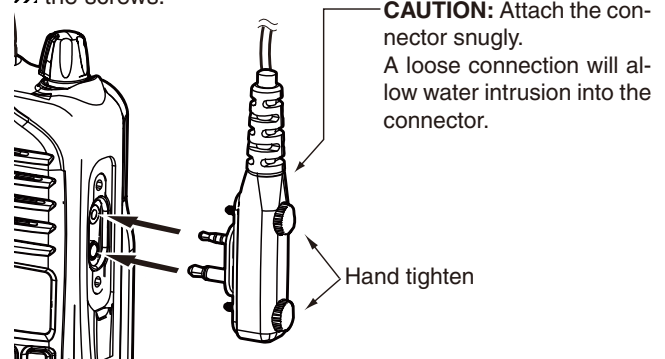

**IMPORTANT:** Keep the [SP MIC] jack cover attached to the transceiver when the speaker-microphone is not in use.

◇ **BATTERY PACK**

Battery pack	Voltage	Capacity	Battery life*
<b>BP-232WP</b>	7.4 V	2250 mAh (min.) 2300 mAh (typ.)	15.0 hrs.

\*When the power save function is turned ON, and the operating periods are calculated under the following conditions;

TX : RX : standby = 5 : 5 : 90

◇ **CHARGERS**

- **BC-119N** DESKTOP CHARGER + **AD-106** CHARGER ADAPTER + **BC-145SV** AC ADAPTER

For rapid charging of battery packs. An AC adapter is supplied with the charger.

Charging time: approximately 3 hours.

- **BC-121N** MULTI-CHARGER + **AD-106** CHARGER ADAPTER (6 pcs.) + **BC-157S** AC ADAPTER

For rapid charging of up to 6 battery packs (six AD-106's are required) simultaneously. An AC adapter should be purchased separately.

Charging time: approximately 3 hours.

- **BC-160** DESKTOP CHARGER + **BC-145SV** AC ADAPTER

For rapid charging of battery packs. An AC adapter is supplied with the charger.

Charging time: approximately 3 hours.

◇ **BELT CLIPS**

- **MB-93** SWIVEL BELT CLIP

- **MB-94** BELT CLIP

Exclusive alligator-type belt clip.

- **MB-96N/96F** LEATHER BELT HANGER

◇ **DC CABLES**

- **CP-23L** CIGARETTE LIGHTER CABLE

Allows charging of the battery pack through a 12 V cigarette lighter socket. (For BC-119N/BC-160)

- **OPC-515L/OPC-656** DC POWER CABLES

Allows charging of the battery pack using a 13.8 V power source instead of the AC adapter.

OPC-515L: For BC-119N/BC-160

OPC-656 : For BC-121N

◇ **OTHER OPTIONS**

- **HM-168LWP** SPEAKER-MICROPHONE

Combination speaker-microphone that provides convenient operation while hanging the transceiver from your belt.

- **FA-SC72U** ANTENNA

470–520 MHz

- **FA-SC73US** STUBBY ANTENNA

450–490 MHz

- **AD-98FSC** ANTENNA CONNECTOR ADAPTER

- **CS-41S** CLONING SOFTWARE + **OPC-478UC** CLONING CABLE

Provide quick and easy programming of such settings as RX frequencies and Set modes contents.

Approved Icom optional equipment is designed for optimal performance when used with an Icom transceiver.

Icom is not responsible for the destruction or damage to an Icom transceiver in the event the Icom transceiver is used with equipment that is not manufactured or approved by Icom.

# 12 SPECIFICATIONS

## ◇ General

- Frequency coverage
  - TX : 450–480 MHz  
(includes all 80 CB channels)
  - RX : 450–520 MHz
- Mode : 8K50F3E/16K0F3E
- Channel spacing
  - CB channel : 12.5 kHz
  - Private channel : 12.5/25 kHz
- Current drain (at 7.2 V) : TX (at 5 W) 1.9 A  
Max. audio 300 mA max.
- Power supply requirement : 7.2 V DC nominal\*  
(negative ground)  
\*Specified Icom's battery pack only
- Frequency stability :  $\pm 2.5$  ppm ( $-30^{\circ}\text{C}$  to  $+60^{\circ}\text{C}$ )
- Antenna impedance : 50  $\Omega$  nominal
- Dimensions : 53.0(W)  $\times$  120(H)  $\times$  37(D) mm  
(Projections not included)
- Weight : Approx. 310 g (including BP-232WP)

## ◇ Transmitter

- Output power : 5 W
- Modulation system : Variable reactance frequency modulation
- Max. frequency deviation :  $\pm 2.5$  kHz/ $\pm 5.0$  kHz
- Spurious emissions : 70 dB (min)
- Adjacent channel power : 68 dB/75 dB (typical)
- External mic. connector : 3-conductor 2.5 (d) mm/2.2 k $\Omega$

## ◇ Receiver

- Receive system : Double conversion superheterodyne
- Sensitivity (12 dB SINAD) : 0.25  $\mu\text{V}$  (typical)
- Squelch sensitivity : 0.25  $\mu\text{V}$  (typical; Threshold)
- Intermodulation rejection ratio : 74 dB (typical)
- Spurious response rejection ratio: 70 dB (min)
- Adjacent channel selectivity : 65 dB/75 dB (typical)
- Audio output power : 0.5 W (typical) at 5% distortion with an 8  $\Omega$  load
- External speaker connector : 2-conductor 3.5 (d) mm/8  $\Omega$

**All stated specifications are subject to change without notice or obligation.**

# WARRANTY AND REGISTRATION 13

## ICOM LIMITED WARRANTY

Icom Incorporated is proud of its advanced technology and the high quality of workmanship and components included in the production of every product.

Icom (Australia) Pty. Ltd., the authorised Icom Distributor, warrants this Icom product within Australia to be free from defects in material or workmanship for the applicable period indicated below:

- **Radios:**

**Two (2) years** from the date of purchase, (excluding accessories), when purchased from an Australian authorised Icom Dealer.

- **Accessories:**

**One (1) year** from the date of purchase, when purchased from an Australian authorised Icom Dealer.  
(i.e. battery, antenna, battery chargers etc)

Icom (Australia) Pty. Ltd. will, at its discretion, and subject to the terms and conditions stated below, repair or replace any goods or component parts which after examination are found to be defective. Unless otherwise expressly provided, any fault arising from defective workmanship or material shall be rectified by Icom where the equipment is returned freight prepaid to Icom, Service Dept. Unit 1/103 Garden Road, Clayton, Victoria 3168

### **This warranty shall not apply:**

- (a) To an Icom Product which has failed due to improper installation, misuse, accident, alteration or unauthorised repair or modification.
- (b) If any serial number or identification plate attached to the goods has been altered, rendered illegible, or removed
- (c) If the goods have been damaged by corrosion, deterioration or the like contributed to abnormal temperatures; the influence of foreign matter or energy or physical or chemical properties of water, steam or chemical compounds.

To any Icom product not originally supplied by Icom (Australia) Pty Ltd to an authorized Dealer of Icom (Australia) Pty. Ltd.

**Please check with us if you feel an Icom product is being offered for sale that has been sourced from other than Icom (Australia) Pty Ltd.**

## WARRANTY SERVICE INSTRUCTIONS

1. If you are experiencing difficulty with your Icom equipment return it to Icom (Australia) Pty. Ltd., preferably in the original carton, without accessories and include a brief explanation of the difficulty you are experiencing. Although we take the utmost care Icom (Australia) Pty. Ltd. shall assume no liability for the loss or safe return of an accessory item.
2. Include accessories only if your specific situation indicates an accessory related difficulty exists. It is important to itemise these accessories on the note of explanation.
3. If the requested repairs or service are within the terms of the warranty, your equipment will be repaired and returned prepaid to any designated point within Australia. The freight carrier is at the option of Icom (Australia) Pty Ltd.
4. If the requested repairs or service are not within the terms of warranty or if you fail to provide acceptable evidence of the date of purchase you will be contacted with a quote to repair your equipment. Return freight will be charged in this instance.
5. All equipment returned under warranty must be freight prepaid. Freight collect packages will not be accepted.

The benefits conferred by this warranty are in addition to all implied warranties, other rights and remedies in respect of the product which the consumer has under the Trade Practices Act and similar State and Territory Laws.

## PRODUCT REGISTRATION

Please log on to [www.icom.net.au](http://www.icom.net.au) to register your Icom product, or complete & return the registration reply page.





Please fold and tape closed

# icom

**REGISTRATION CARD**

PLACE  
POSTAGE  
HERE

---

---

---

**Icom (Australia) Pty. Ltd.**

**Unit 1/103 Garden Road  
Clayton VIC 3168**

Cut here

## Product and Owners detail

Model No: \_\_\_\_\_ Serial No: \_\_\_\_\_ Date of Purchase: \_\_\_\_\_

Dealers Name: \_\_\_\_\_

Purchasers Name: \_\_\_\_\_

Purchasers Address: \_\_\_\_\_

Email: \_\_\_\_\_ Contact Phone No: \_\_\_\_\_ Occupation: \_\_\_\_\_

## Answering the following question will better help us meet your future needs:

In what media have you seen ICOM Advertising?

Newspaper  Magazine  TV  Radio  Website Other: \_\_\_\_\_

Magazines you regularly purchase and/or subscribe to: \_\_\_\_\_

I would like more information on the following:

Air Band  Amateur  Commercial Radios  Marine  Receiver  UHF CB

Other Radio Communications Equipment you use: \_\_\_\_\_

Comments: \_\_\_\_\_

\_\_\_\_\_

\_\_\_\_\_

Thank you for completing this Registration, we feel confident you will enjoy many years of superior performance your Icom equipment provides.

---

MEMO

---

---

---

---

---

---

---

---

---

---

---

---

---

---

---

---

---

---

---

---

---

---

---

---

---

---

---

---

---

---

---

---

---

---

---

---

---

---

---

---

---

---

---

---

---



MEMO

Lined writing area on the left side of the page, consisting of 15 horizontal lines.

Lined writing area on the right side of the page, consisting of 15 horizontal lines.



---

MEMO

---

---

---

---

---

---

---

---

---

---

---

---

---

---

---

---

---

---

---

---

---

---

---

---

---

---

---

---

---

MEMO

---

---

---

---

---

---

---

---

---

---

---

---

---

---

---

---

---

---

---

---

---

---

---

---

---

---

---

---

**Count on us!**

A-7000D-1AU  
Printed in Japan  
© 2012 Icom Inc.

Printed on recycled paper with soy ink.

**Icom Inc.**

1-1-32 Kamiminami, Hirano-ku, Osaka 547-0003, Japan