

# SPEED TIMES

Issue 66 - August 2019

**THE OFFICIAL NEWSLETTER OF THE DLRA**



## SPEED WEEK 2020

Speed Week 2020 will be our 30th Anniversary event!

ENTRIES will OPEN in October 2019 and CLOSE on 09/02/2020.

And Entrants don't forget to nominate for your volunteer job, it is mandatory for all entrants or a team member to volunteer. As always, spectators are very welcome to volunteer as well.

## FROM THE CHAIR

Congratulations to Mick Hite #241 and Greg Telford #1049 who feature on the 30th Anniversary Speed Week logo. Two very deserving recipients. Mick has been competing since 2000 and has broken five records in that time. Greg built his Holden grey motor belly tank and has been racing since 2015, having broken 3 records. He has also been our event co-ordinator for set up and pack up for most of that time.

Hard to believe it's now 30 years since nine blokes took their cars out on to Lake Gairdner and went as fast as they could. Each year has seen gradual improvements in the organisation of the event and the number of entrants rise. There are not many motoring enthusiasts who are now not aware of Speed Week and it has truly become a "bucket list" activity for many people. The improvements we have made make it more accessible for many people and the equipment we use now is world class. Many of our Australian based entrants make the journey to the States and we enjoy the company and competition with many entrants from around the world. It just doesn't get any better than this.

Organisation for Speed Week 2020 is well under way, our damaged timing equipment has returned from Switzerland and we have taken the opportunity to include some upgrades to the chronoprinters which will give us some welcome flexibility. We have also now purchased a new (to us) generator to replace the camp generator which so spectacularly threw a leg out of bed and caught fire this year. The trucks and tractor are all undergoing repairs and servicing and will be ready to perform their very valuable roles again in 2020.

Greg Wapling  
DLRA President  
0434 821 307  
president@dlra.org.au

## WORLD SPEED TRIALS AUSTRALIA

On the back of the very successful 2018 event where four world records were broken, the DLRA are proposing to hold another World Speed Trials Australia as part of the 30th Anniversary celebrations. This time it will be a combined car and bike event.

It will be run immediately after Speed Week from the 28th to 30th March 2020.

Expressions of Interest have already been advertised and this has already attracted 15 motorcycle and two car teams wanting to make world record attempts.

Negotiations have already begun with the Fédération Internationale de l'Automobile (FIA) and their Australian affiliate the Confederation of Australian Motorsport and the Fédération Internationale de Motocyclisme (FIM) and it's Australian affiliate Motorcycling Australia (MA).

The intent is to make this a cost neutral event for the DLRA. As you can imagine there are significant costs involved and we are currently seeking sponsorships to make this possible. This is an amazing opportunity for sponsors to be associated with this high-profile event.

If you or someone you know maybe interested in supporting this once in a lifetime event, please contact Greg Wapling, president@dlra.org.au or 0434 821 307. It is our endeavour to provide as much value as we can in return for our sponsors.

## DLRA CAMP WORKING BEE

**WHAT: DLRA Camp Working Bee**

**WHEN: 2nd - 5th November 2019**

**WHERE: DLRA Camp, Lake Gairdner, South Australia**

The DLRA Camp working Bee will be held from 2nd to 5th November 2019. There are few jobs to be done to keep the place neat and tidy and as we all know, many hands makes for light work. Plus it's a great time of the year to be in the outback. Everyone is welcome. Contact Greg Telford on 0402 801 627 or Carol 03 5472 4629.

**P.S.** As an incentive, those that work at the Working Bee get free accommodation for the next Speed Week.

## DASH PLAQUES

Official DLRA Dash Plaques are available to all entrants who have made a pass on the lake. The plaques are made of aluminium, approximately 75 mm by 50 mm in size with the DLRA belly tank logo and will be engraved with your details. Sorry we will not sell blanks.

Download the order form, complete the details, and send it in to: <http://www.dlra.org.au/timing-plaques.htm>

Plaques are done in batches of ten, so out of season, it may take a while. Just \$30.00 including postage.



## RULE BOOK

The 2020 DLRA Rule Book is now published and available for download at <https://www.dlra.org.au/rulebook.htm>

There are a number of changes so I would strongly advise entrants to download and read the document. There are two versions available for download; a print version (fine for viewing on the desktop) and a large print version (ideal for viewing on your phone).

**PLUS:** this year there is a summary document of all the changes to the rule book, this will also be inserted into the printed version until we run out of 2019 rule books.

You can download the insert at: <https://www.dlra.org.au/docs/2020dlra-rulebook-insert.pdf>

## ENGINE SEALS

As some of you will be aware the DLRA technical inspectors have been using engine seals when the capacity of an engine has been checked and a record attempt is being made. What we want to try now is offer entrants to get their motors sealed either by their engine builder or a recognised inspector prior to coming to Speed Week saving both the entrant and the technical inspectors valuable time. The plan is to tap into the Australia wide program used by the Speedway fraternity. Look for more information on this soon or contact: [info@dlra.org.au](mailto:info@dlra.org.au)

## DLRA MERCHANDISE

Speed Week merchandise will be available soon!

We will be offering event T-shirts in grey and will also be selling some polo shirts (logo on the back) by special order. Plus, all the regular club merchandise. Download the order form on the merchandise page [www.dlra.org.au/merchandise.htm](http://www.dlra.org.au/merchandise.htm)

**T-shirt, White \$36.00:** Mens - S to 5XL or Ladies - 10 to 18

**T-shirt, Black \$36.00:** Mens - S to 5XL or Ladies - 10 to 18

**Singlets, Black \$20.00:** Mens - S-XL or Ladies - 12-16

**Stubbie Holders \$12.00**

**2020 Stickers \$2.00**

**Metal Signs \$45.00**



T-shirt, White \$36  
Mens - S to 5XL  
Ladies - 10 to 18



T-shirt, Black \$36  
Mens - S to 5XL  
Ladies - 10 to 18



Singlets, Black \$20  
Mens - S-XL  
Ladies - 12-16



Stubbie Holders \$12.00



2020 Stickers \$2.00



Metal Signs \$45.00

## BUY, SWAP, SELL



**FOR SALE - VEHICLE SCALES:** A set of four heavy duty vehicle scales (seven ton max. each) Just been serviced. No longer required. \$400.00 for the set of four.

**WANTED – PALLET HOOK:** Similar to that shown (right), willing to pay up to a couple of hundred dollars.

Contact: Greg 0434 821 307 or email: [info@dlra.org.au](mailto:info@dlra.org.au)

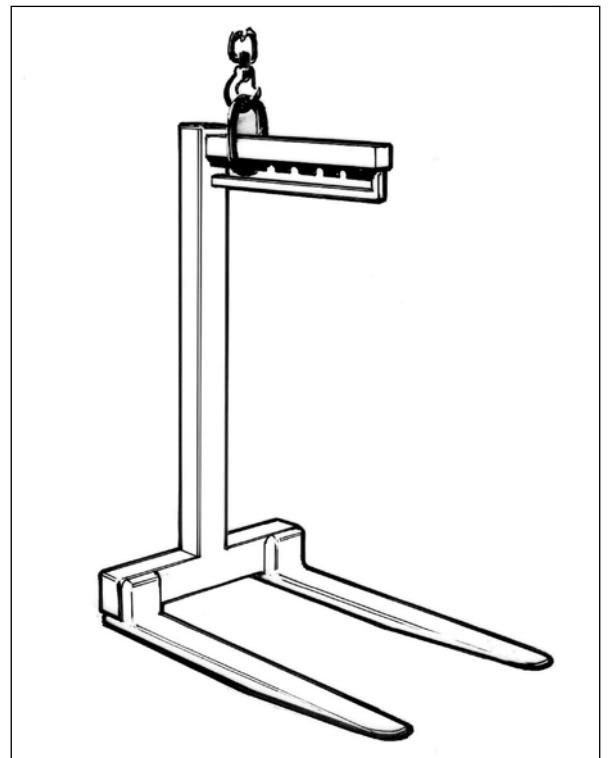

## Thanks to our Sponsors

Welcome to our new Newsletter Sponsor, the Excelsior Tooling Company and their amazing range of high-end tool cabinets. [www.excelsiortooling.com](http://www.excelsiortooling.com)



**INSPIRED BY AN ERA.  
BROUGHT TO LIFE  
BY PASSION.**

Constructed in heavy gauge steel throughout, welded and bolted into rock-solid integrated units, the Excelsior range of products is made to last generations.

All products are powdercoated in a range of standard colors and can be completed with your choice of options.

And as they're modular, you can create a solution to perfectly fit your requirements.

For further information, visit the website or email us at [info@excelsiortoolingcc.com](mailto:info@excelsiortoolingcc.com)

**Excelsior**  
EXCELSIORTOOLING.COM



## DLRA CALENDAR

**WHAT: DLRA Camp Working Bee**  
**WHEN: 2nd – 5th November 2019**  
**WHERE: DLRA Camp, Lake Gairdner, South Australia**

**WHAT: General Meeting in Victoria**  
**WHEN: Sunday 15th December 2019**  
**WHERE: Northern Suburbs Hot Rod Club Rooms, 25/196 Settlement Road, Thomastown**  
Meeting will start at 11:00am sharp, should all be over by 3:00pm. Barbecue after, \$5.00 per head for sausages in bread, salads, and a soft drink.  
If you wish to get a pre-inspection on your vehicle at this meeting, please contact Carol at 03 5472 4629 or [secretary@dlra.org.au](mailto:secretary@dlra.org.au) prior to the above date.

**WHAT: Speed Week 2020**  
**WHEN: Monday 23rd March – Friday 27th March 2020**  
**WHERE: Lake Gairdner, South Australia**  
See website for more details.

**WHAT: FIA and FIM World Speed Trials**  
**WHEN: Saturday 28th – Monday 30th March 2020**  
**WHERE: Lake Gairdner, South Australia**  
To be run under the regulations of the Federation Internationale de l'Automobile and it's Australian associate the Confederation of Australian Motor Sport, running international record attempts in FIA classes. And the Fédération Internationale de Motocyclisme and it's Australian associate, Motorcycling Australia, running world record attempts in FIM classes. IMN number is yet to be announced.  
The cost per entry is yet to be determined. If the event is cancelled before the 1st of February entrants will get 50% of their entry fee back. After that no money back.  
NOTE: Each entrant will need to submit their own world record attempt documentation with the FIA or FIM.  
See website for more details on this event.

Keep in touch with Dry Lakes Racers Australia  
<http://www.dlra.org.au>  
Facebook at <https://www.facebook.com/DryLakesRacersAustralia/>